



Technical brochure

- Handling Systems

Date: 04/2022



STROTHMANN
Machines & Handling

Line gantries

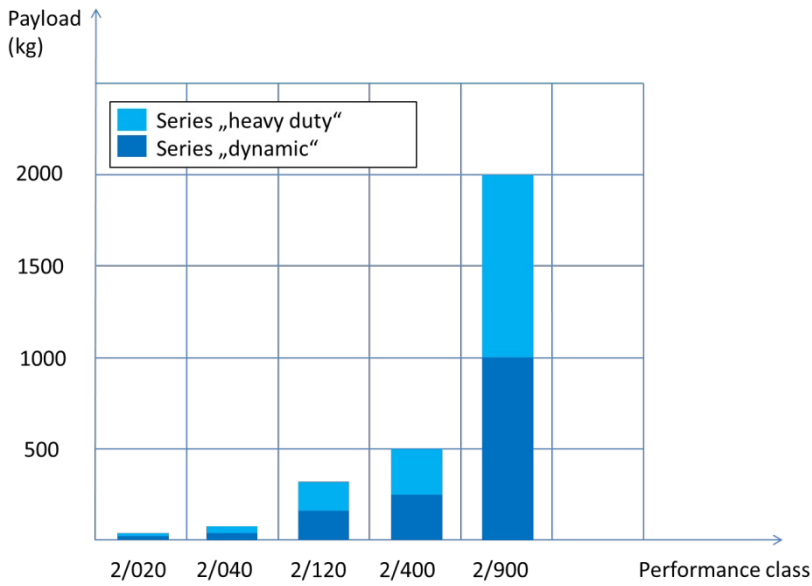

| | 2/020 |
|--|-------------------|
| Load capacity highly loaded | 50kg |
| Dynamic load capacity | 25kg |
| Max. stroke Y | 6400*mm |
| Max. stroke Z | 1500*mm |
| Max. support span highly loaded | 4500mm |
| Max. dynamic support span | 3500mm |
| Support structure | Aluminium profile |

* Further lengths on request



Maximum speed and acceleration

| Load case | Speed Y [m/s] | Acceleration Y [m/s ²] | Speed Z [m/s] | Acceleration Z [m/s ²] |
|---------------|---------------|------------------------------------|---------------|------------------------------------|
| Highly loaded | 3 | 7,5 | 2 | 5 |
| Dynamic | 3 | 10 | 2 | 10 |

Drives and guiding system

| Axis | Guiding system | Drive |
|------|----------------|------------|
| Y | Track roller | Tooth belt |
| Z | Track roller | Tooth belt |

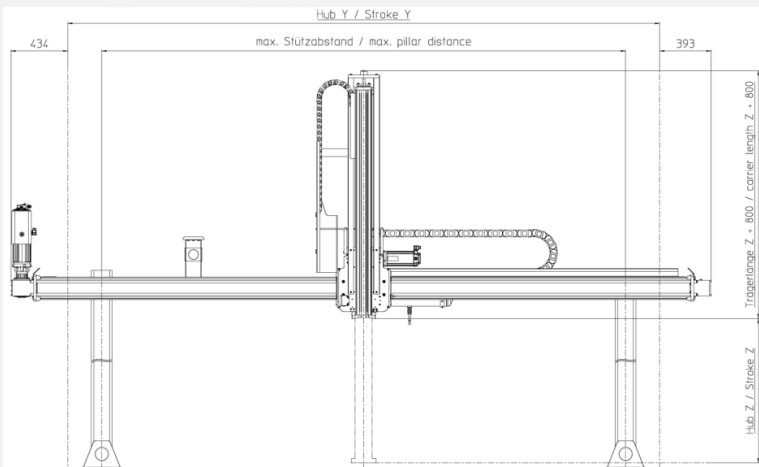

Line gantries

2/040

| | |
|--|--------------------------------------|
| Load capacity highly loaded | 100kg |
| Dynamic load capacity | 50kg |
| Max. stroke Y | 6300*mm (with steel girder 12500*mm) |
| Max. stroke Z | 1700*mm |
| Max. support span highly loaded | 5500mm |
| Max. dynamic support span | 4500mm |
| Support structure | Aluminium profile or steel girder |

* Further lengths on request

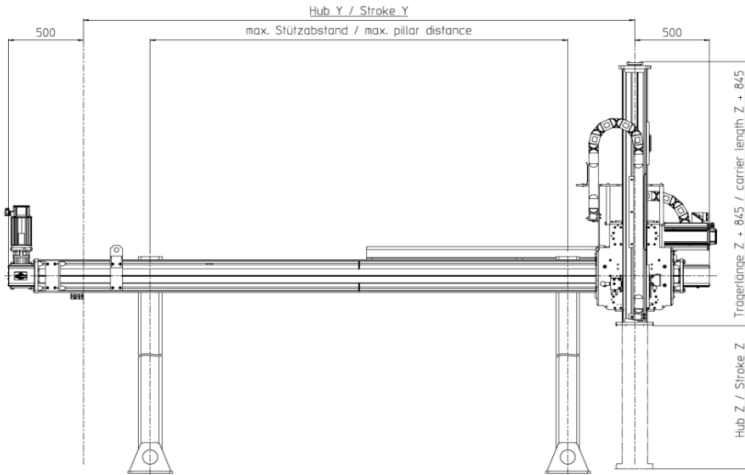

Maximum speed and acceleration

| Load case | Speed Y [m/s] | Acceleration Y [m/s ²] | Speed Z [m/s] | Acceleration Z [m/s ²] |
|---------------|---------------|------------------------------------|---------------|------------------------------------|
| Highly loaded | 3,75 | 5 | 2 | 5 |
| Dynamic | 3,75 | 10 | 2 | 10 |

Drives and guiding system

| Axis | Guiding system | Drive |
|------|----------------|------------|
| Y | Track roller | Tooth belt |
| Z | Track roller | Tooth belt |



2/120

| | |
|--|--------------|
| Load capacity highly loaded | 300kg |
| Dynamic load capacity | 150kg |
| Max. stroke Y | >50000*mm |
| Max. stroke Z | 1700*mm |
| Max. support span highly loaded | 8000mm |
| Max. dynamic support span | 5500mm |
| Support structure | Steel girder |

* Further lengths on request

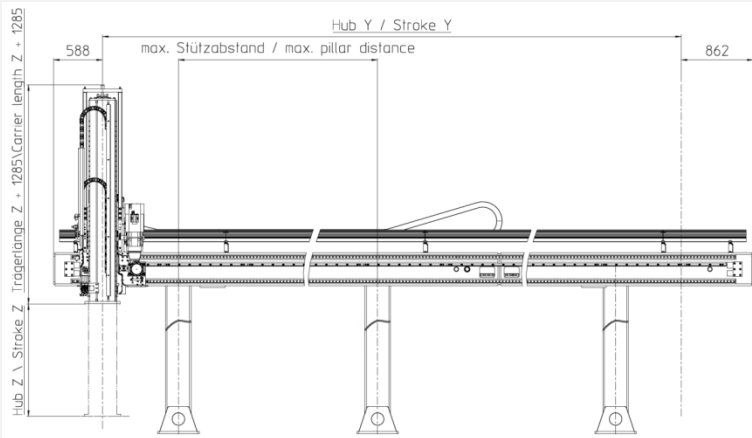

Maximum speed and acceleration

| Load case | Speed Y [m/s] | Acceleration Y [m/s ²] | Speed Z [m/s] | Acceleration Z [m/s ²] |
|---------------|---------------|------------------------------------|---------------|------------------------------------|
| Highly loaded | 4,5 | 5 | 1,75 | 5 |
| Dynamic | 4,5 | 10 | 1,75 | 10 |

Drives and guiding system

| Axis | Guiding system | Drive |
|------|----------------|-------------|
| Y | Profile rail | Pinion/Rack |
| Z | Profile rail | Tooth belt |

Line gantries

2/400

| | |
|---------------------------------|--------------------|
| Load capacity highly loaded | 300kg |
| Dynamic load capacity | 250kg |
| Max. stroke Y | >50000*mm |
| Max. stroke Z | 2600*mm |
| Max. support span highly loaded | 8000mm |
| Max. dynamic support span | 8000mm |
| Support structure | Steel girder |
| Vertical axis | Telescopic version |

* Further lengths on request



Series 2/400

Maximum speed and acceleration

| Load case | Speed Y [m/s] | Acceleration Y [m/s ²] | Speed Z [m/s] | Acceleration Z [m/s ²] |
|---------------|---------------|------------------------------------|---------------|------------------------------------|
| Highly loaded | 3,2 | 2,5 | 1,5 | 2,5 |
| Dynamic | 3,2 | 5 | 1,5 | 5 |

Drives and guiding system

| Axis | Guiding system | Drive |
|------|----------------------------------|-------------|
| Y | Track roller | Pinion/Rack |
| Z | Recirculating ball bearing guide | Tooth belt |

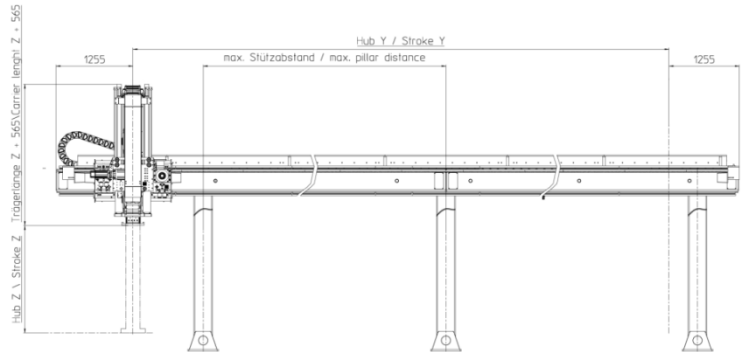

Series 2/900

2/900

| | |
|---------------------------------|--------------|
| Load capacity highly loaded | 2000kg |
| Dynamic load capacity | 1000kg |
| Max. stroke Y | >50000*mm |
| Max. stroke Z | 3000*mm |
| Max. support span highly loaded | On request |
| Support structure | Steel girder |

* Further lengths on request

Maximum speed and acceleration

| Load case | Speed Y [m/s] | Acceleration Y [m/s ²] | Speed Z [m/s] | Acceleration Z [m/s ²] |
|---------------|---------------|------------------------------------|---------------|------------------------------------|
| Highly loaded | 2,5 | 2,5 | 2 | 2,5 |
| Dynamic | 2,5 | 10 | 2 | 5 |

Drives and guiding system

| Axis | Guiding system | Drive |
|------|----------------------------------|-------------|
| Y | Track roller | Pinion/Rack |
| Z | Recirculating ball bearing guide | Tooth belt |

Traversing feeders

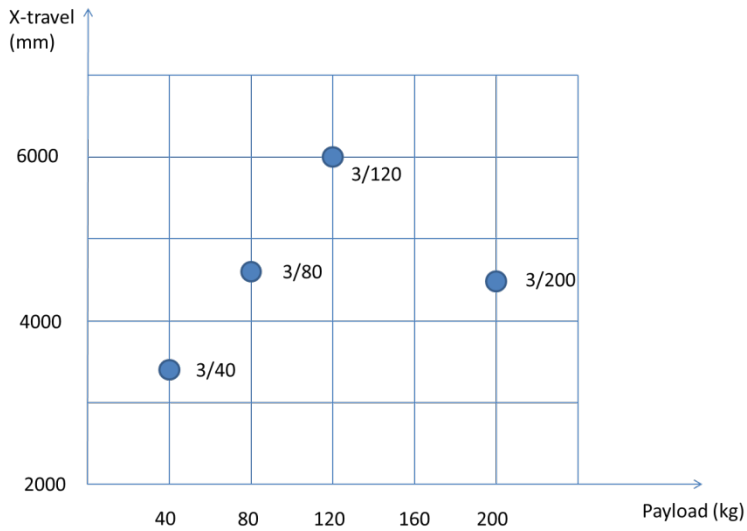

3/040

| | |
|---|----------|
| Load capacity | 70kg |
| Max. Load capacity with reduced dynamics | 100kg |
| Max. Stroke X | 3300*mm |
| Max. Stroke Y | 20000*mm |
| Max. Stroke Z | 1000*mm |

* Further lengths on request

Maximum speed and acceleration

| | Speed [m/s] | Acceleration [m/s ²] |
|--------|-------------|----------------------------------|
| Axis X | 6 | 15 |
| Axis Y | 1,5 (3,5)** | 7,5 (3,5)** |
| Axis Z | 1,5 | 7,5 |

* Further lengths on request
 ** For long Y-distance

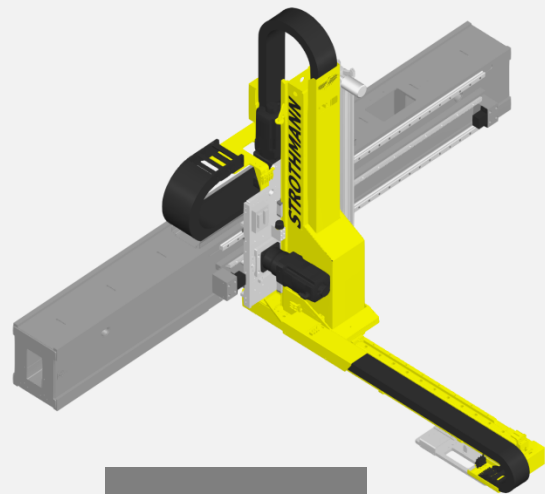

Series 3/040

Traversing feeders

3/080

| | |
|---|----------|
| Load capacity | 100kg |
| Max. Load capacity with reduced dynamics | 200kg |
| Max. Stroke X | 4700*mm |
| Max. Stroke Y | 20000*mm |
| Max. Stroke Z | 1000*mm |

* Further lengths on request

Maximum speed and acceleration

| | Speed [m/s] | Acceleration [m/s ²] |
|--------|-------------|----------------------------------|
| Axis X | 6 | 15 |
| Axis Y | 1,5 (3,5)** | 7,5 (3,5)** |
| Axis Z | 1,5 | 7,5 |

* Further lengths on request

** For long Y-distance



Series 3/080

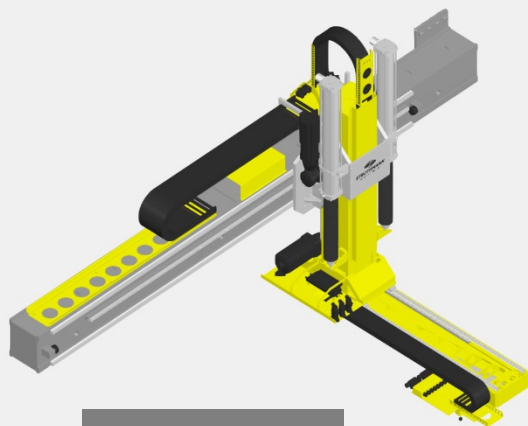

Series 3/120

3/120

| | |
|---|----------|
| Load capacity | 120kg |
| Max. Load capacity with reduced dynamics | 250kg |
| Max. Stroke X | 4500*mm |
| Max. Stroke Y | 20000*mm |
| Max. Stroke Z | 1100*mm |

* Further lengths on request

Maximum speed and acceleration

| | Speed [m/s] | Acceleration [m/s ²] |
|--------|-------------|----------------------------------|
| Axis X | 7 | 20 |
| Axis Y | 1,5 (4)** | 7 (4)** |
| Axis Z | 1,5 | 7,5 |

* Further lengths on request

** For long Y-distance

3/200

| | |
|---|----------|
| Load capacity | 250kg |
| Max. Load capacity with reduced dynamics | 350kg |
| Max. Stroke X | 4500*mm |
| Max. Stroke Y | 20000*mm |
| Max. Stroke Z | 1100*mm |

* Further lengths on request

Maximum speed and acceleration

| | Speed [m/s] | Acceleration [m/s ²] |
|--------|-------------|----------------------------------|
| Axis X | 7 | 13,5 |
| Axis Y | 1,5 (4)** | 6,5 (4)** |
| Axis Z | 1,5 | 7,5 |

* Further lengths on request

** For long Y-distance

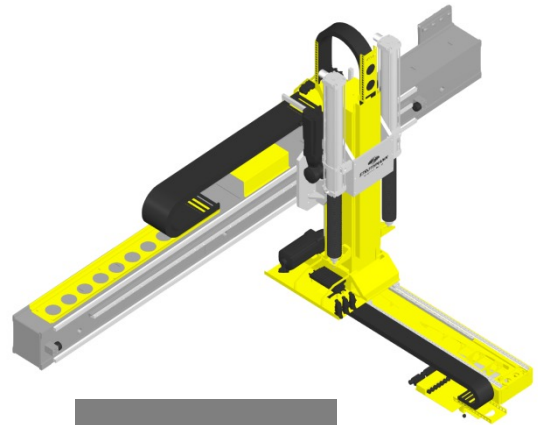

Series 3/200