

We are proud to be the partner of many top-tier companies
(An extract from our list of references)

- Benteler
- Changan Ford
- Geely
- Gestamp
- Kirchhoff Automotive
- Loire
- Magna
- Telos Global

Strothmann Maschines & Handling GmbH

Altenkamp 11
33758 Schloß Holte-Stukenbrock
Germany
Tel.: +49 (0) 5207 / 9 122-0
sales@strothmann.com
A member of the Siempelkamp group.



YOUR SPECIALIST FOR
AUTOMATION SOLUTIONS

Press Hardening



Information about the quality and application of products does not constitute a guarantee of properties, but is only intended for information purposes. The decisive factor for the scope of our delivery is the respective contract portfolio

In the past decades, *STROTHMANN* has specialised in the automation of pressing plant processes. Notable automotive manufacturers and suppliers worldwide put their trust in *STROTHMANN*.

Our motto is "Innovation in Motion". This represents the constant further development of our products and services. We are not afraid to journey down new, unconventional paths in order to ensure the competitive advantage of our customers. Years of experience, our membership in the Siempelkamp group and the down-to-earth outlook of a company from the Eastern Westphalia region are what makes us a reliable partner.

Our services include:

- Research
- Development
- Planning
- Training
- Service
- Production support
- Simulation
- Design
- Production
- Assembly
- Commissioning
- Programming

Our employees are the key to the high quality of our automation solutions. We provide our expert staff with professional training in various fields. We also ensure that our experienced employees receive continuous further education.

Press hardening is used with great success in automotive production worldwide. In the past 10 years we have witnessed incredible growth in new hot forming lines and the boom continues.

STROTHMANN has equipped over 60 hotforming lines worldwide with automation solutions, meaning our company has years of experience in this field. We collaborate with numerous well-established machine line manufacturers throughout the world.



Strothmann offers the following solutions:

- Front-of-Line
- Hydraulic marking station
- Servo centring station
- Press loading and unloading feeder
- Automatic stacking station
- Condition Monitoring

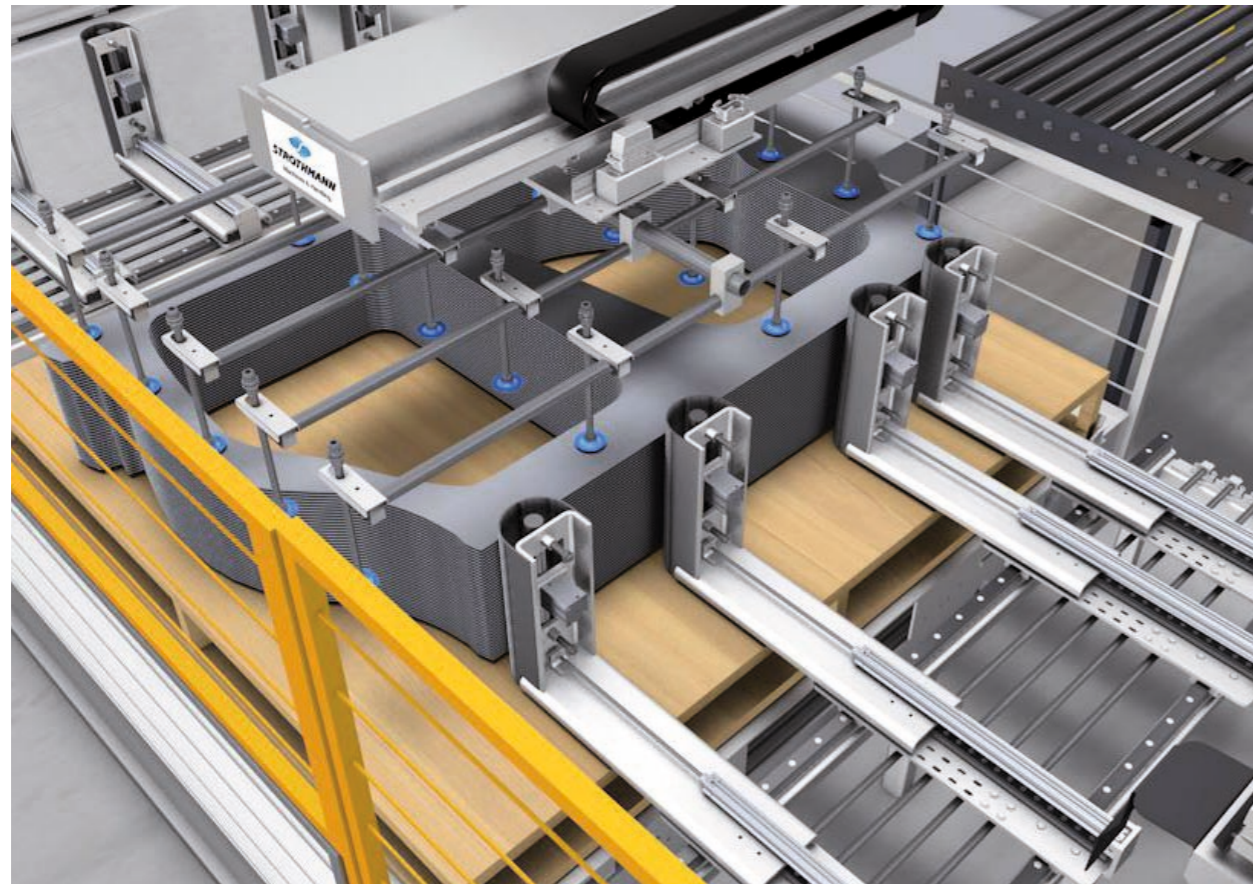

Spreading station with pneumatically cycling magnets and manual side adjustments

Blanks are supplied on blank carts or stationary deposit tables, depending on the customer's request. The blank carts move along the tried and tested STROTHMANN RoundTrack. One of the numerous advantages is that the rails are very flat and can therefore be crossed by industrial trucks without any problems.

The spreading magnets can either be adjusted manually or are moved automatically.



Blank destacking with magnetic spreading station

Thanks to independent safety zones in the destacking cells, the supply is continuous, even if stack changes are required.

Feeders or alternatively robots can be used for blank destacking.

Depending on the selected handling device and blank provision, the blanks can be gripped as a complete batch. Alternatively, the batch can be composed of different blank carriages.

If desired, the blanks are centred. In general, we use centring stations with centring mandrels for this purpose.



Blank destacking using pantograph arms mounted on the blank carts.



Blank destacking with double feeders and 4 blank carriages

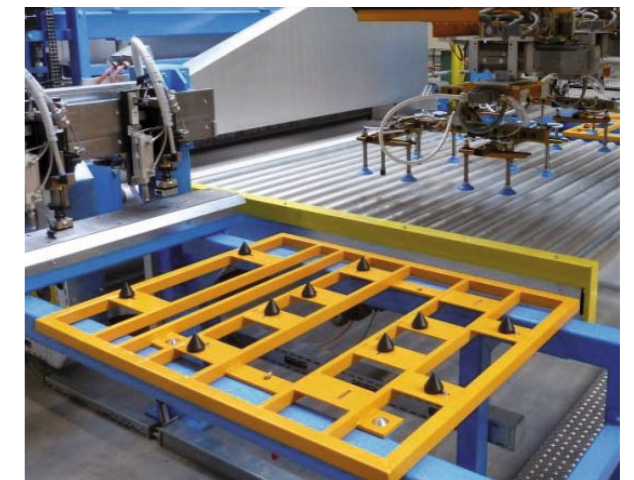

Centring stations with centring mandrels

Advantages at a glance:

- Significant cycle time advantage compared with robots
- Time-tested heavy-duty feeder
- Simple and precise infeed of the blank carriages on STROTHMANN RoundTracks
- Blank-free individual configuration possible
- Efficient centring station
- Simple integration of the markingstation



Hydraulic marking station with 2 heads arranged on opposite sides, lengthwise and crosswise

Compared with conventional, pneumatic marking stations, the hydraulic marking station of STROTHMANN offers significant advantages:

The hydraulic ram is gentle and quiet and only causes minor load on the mechanical system compared with conventional spring-loaded marking devices. These are very loud and cause great impacts with every stamping movement, which must be absorbed by the mechanical system.

Its modular layout permits the use of any number of heads per number of blanks per batch. If necessary, additional heads can be retrofitted at a later point. This permits simultaneous marking of all blanks.

As marking units can also be arranged opposite of each other, both blank ends can be marked without rotation, reducing processing time significantly.

The spacing between the units in the lengthwise and crosswise direction can be adjusted manually or automatically. This permits quick and simple adaptation of the units to different batch configurations. It also reduces the cycle time.

All units move on the pre-tensioned linear guides, which is crucial for accurate marking

A linear path measurement system on each hydraulic cylinder automatically checks the thickness of the sheet metal prior to each marking process. This ensures that double blanks are detected

Marking can consist of up to 26 letters. This permits engraving of any label or large-format logo.

As an option, the marking stamp can count up by one digit after marking.

The hydraulic pressure value is part of the tool data and is automatically adjusted to the number of marking letters and the logo size. The result is a consistent marking quality at all times.

The hydraulic unit is dimensioned so that marking only takes 1.7 seconds. This means marking has no effect on the overall cycle time.

The complete marking station is heat-protected, so that it can be positioned in a space-saving manner directly in front of the furnace opening.

Advantages at a glance:

- Consistent marking quality
- Very quiet
- Up to 26 letters and logos possible
- Low cycle time
- Integrated double blank check
- Quick adaptation to different blank sizes



Flexible, modular centring station with servo-controlled centring fingers

Compared with conventional centring stations using pneumatic centring fingers, the servo centring station of STROTHMANN offers significant advantages:

Each centring finger is positioned on a separate linear unit with a servo drive, which can be shifted manually in the throughfeed direction.

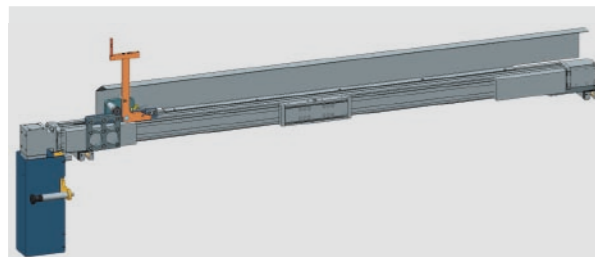

Servo linear unit with centring finger

The closing movement of each individual centring finger is generated by its own servo motor. This ensures that each finger reaches the desired end position during centring, increasing process reliability significantly compared with conventional pneumatic solutions. Moreover, the fingers can be used for extremely quick teaching of new batches and it is possible to set offset values immediately and conveniently by entering them in the control system.

By default, 16 centring fingers are installed for 4-piece batches. Thanks to the modular concept, it is easy to retrofit additional centring units, e.g. to switch to 6-piece batches.

The stop bar installed crosswise in relation to the throughfeed direction can be adjusted to the linear guides in feed direction. If blanks are rejected, it is automatically lifted and the blanks are automatically discharged. Thanks to the integrated T-grooves on the stop bar, part-specific stops are easy to install, adjust and replace with new stops during a tool change. As an option, part-specific stops can also be moved with motor power in the lengthwise and crosswise direction.

The transport rollers are connected to a sturdy shaft and are easy to replace. The rollers have a curved contact surface with lateral phase, the contact is minimised, minimising heat loss accordingly. Thanks to the phase, blanks in contact with the side of the roller can be pushed onto the roller during centring.

As an option, the blanks can be lifted by means of a lifting device.

The lift-out struts can either be adjusted manually or by means of a servo motor.

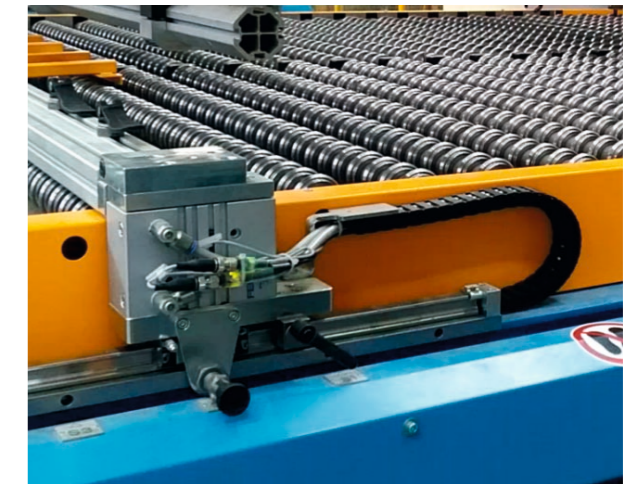

Manually adjustable stop bar

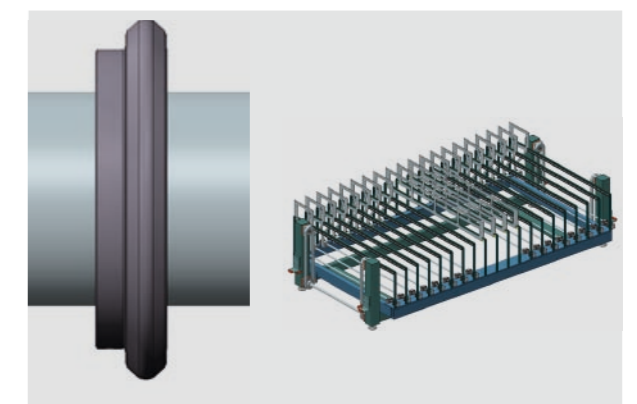

Transport roller

Lift-out device

Advantages at a glance:

- Centring finger driven by a servo motor, increases process reliability
- Quick, convenient teaching process
- Modular concept
- Automatic disposal of reject blanks
- Lifting function as an option
- Quick adaptation to different blank sizes

STROTHMANN provides a wide range of feeders and transfers for hot forming.

They are adapted specifically to extreme ambient conditions (heat, abrasive dust) during the hot forming process and have proven successful in over 60 lines worldwide.



Hot forming transfer 3/80



Hot forming feeder 3/200

	3/40	3/80	3/120	3/200
X-stroke	2.500/3.300 mm	4.000/4.700 mm	6.000 mm	4.500 mm
Y-stroke	1.100 mm	1.100 mm	5.000 mm	5.000 mm
Z-stroke	700 - 1.000 mm	700 - 1.000 mm	800 mm	800 mm
Net load	40 kg	80 kg	120 kg	200 kg

As an option, different strokes are available in X, Y and Z.

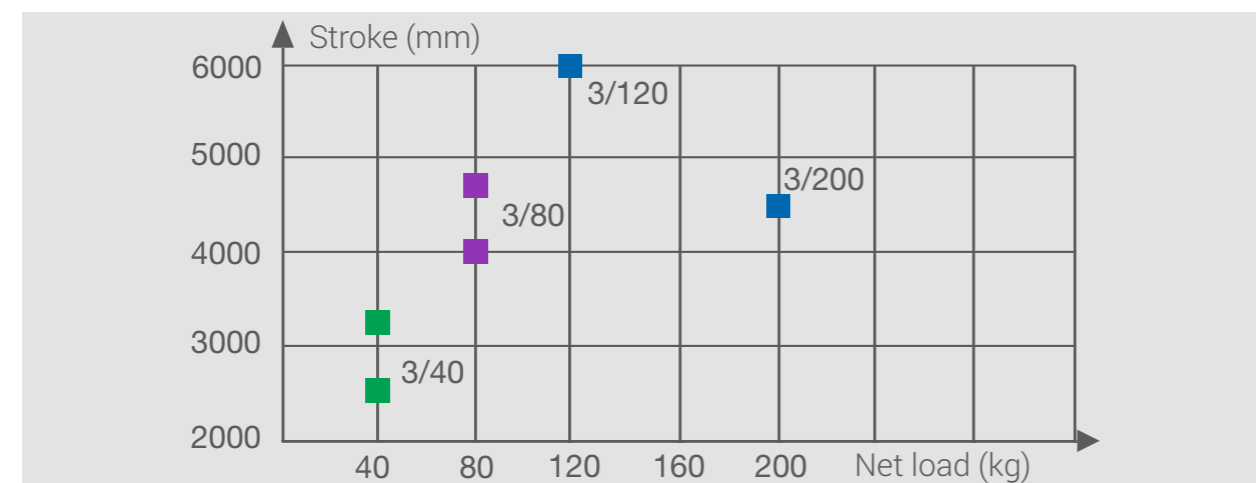

Load-bearing capacities for different X strokes

Loading time

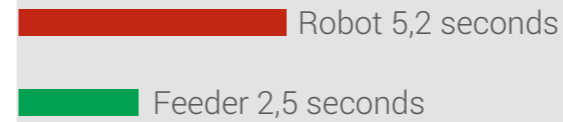

Annual output



Basis: Total cycling time with robot 14 s, pieces falling 4 times, 3-shift operation, 350 work days per year and 80 % machine line availability

Options:

Spreading device under the X2 axis, reducing the blank spacing in the furnace

X2 axis with separate drive, providing additional cycling time optimisation



Short gripper tooling

Advantages of the feeder/transfer compared with a robot:

- Significantly increased output through decreased handling time
- Transfer with tooling can wait next to the tool during forming, if space permits, reducing the cycle time even further
- Simple assembly on the press stands
- Small footprint
- Simplified tooling, if the blanks are gripped on the outer edge

Automatic finished part destacking

Behind the press, an automatic part destacking system places the finished parts in the containers defined for them. This reduces the number of required operators, and also reducing personnel expenses.

It improves safety, as there is no longer any contact of personnel with hot and sometimes sharp-edged blanks.

As we know from experience that our customers requirements vary significantly, there is no standard solution. Each destacking system is tailor-made based on available space, blanks to be processed, container types, cycle time, etc.

The automatic destacking system shown below is designed to deposit up to four blanks into standard lattice boxes simultaneously with a cycle time of 15 s.



Example of automatic finished part destacking for 4-piece batch

Press Hardening

The four blanks are deposited on a shuttle by the unloading feeder. The shuttle approaches the destacking system. Once it has arrived, two robots grip two parts each and deposit them on a temporary deposit point. Each temporary deposit drives into gripping jaws and leaves the blanks there.

This ensures a very high packing density, which cannot be achieved through manual work and means that more blanks can fit in one lattice box, lowering cost accordingly.

Once the gripping jaws have been filled with a complete layer, they enter the lattice box from the top via a linear axis and deposit the complete layer. Once the lattice boxes are filled, the operator replaces them with a new lattice box. During this process, the machine line continues to operate. Uninterrupted operation is ensured.

As an emergency concept, the system is equipped with a centred steel plate hinge belt, on which the unloading feeder deposits the blanks, which then can be destacked manually by operators.

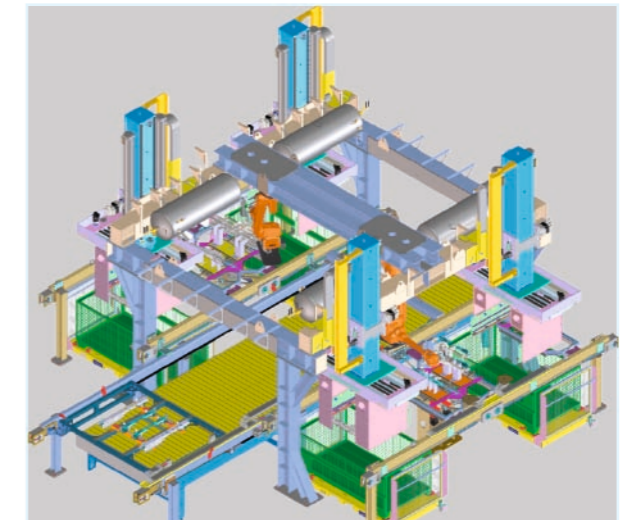

Example of automatic part destacking for 4-piece batch

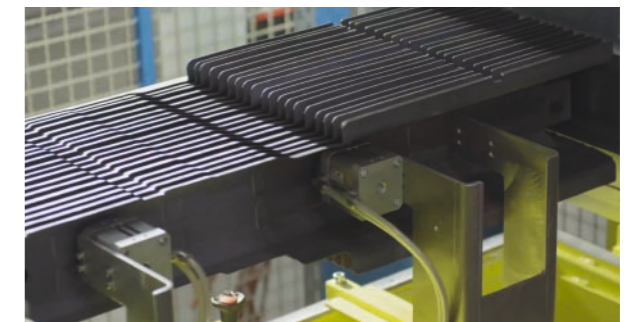

Very high packing density of the destacked finished parts

Advantages at a glance:

- Simple conversion when changing blanks
- Improved safety
- Increased economic efficiency (reduction of personnel expenses)
- Suitable for any hot-formed blanks
- Deposit in universal containers or blank-specific containers
- Increased packing density

The trend toward digitalisation represents a strengthening of communication and co-operation between man and machine with the aim of optimising the entire value added chain.

One step in this direction is permanent monitoring of critical wear parts. For this purpose, STROTHMANN has developed an extensive Condition Monitoring system. It comprises the areas of data acquisition, data evaluation and data visualisation.

These methods are used to derive predictive measures in order to avoid unplanned production downtimes. This creates the following advantages:

- Only truly necessary components are replaced, but they are replaced in time (condition-based maintenance). This leads to a significant reduction in cost compared with conventional preventative maintenance, in which components are replaced irrespective of their actual condition.
- Machine availability is increased even more.

The extent of condition monitoring can be adapted to the individual customer's requirements.

Example 1: Guide carriages of linear guides

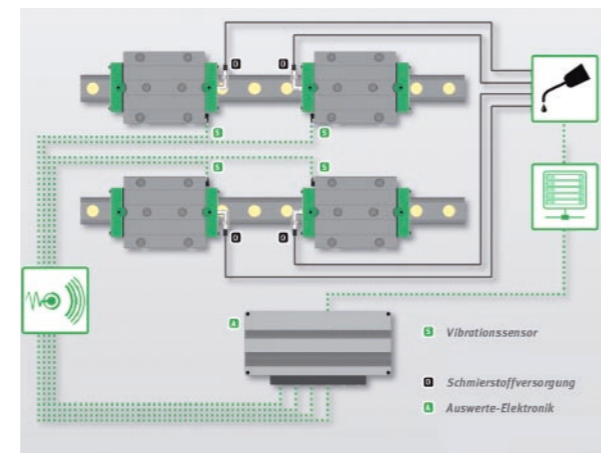

Each guide carriage is equipped with a vibration sensor. The signals of all sensors are collected by an evaluation unit. Depending on the signal type, the system differentiates between:

1. Relubrication required (automatic process)
2. Wear limit is approaching

In case 2, a message is displayed on the operator screen, indicating the remaining service life. This allows the operator to schedule the replacement during a non-production period, thereby avoiding production downtimes.

Example 2: Energy chains

An integrated wear element slides into the chain and touches the moving upper chain strand. After a certain number of cycles, the element is worn and transmits a signal to the machine control system. The remaining service life of the chain is displayed on the screen, making it possible to schedule the replacement.

Moreover, a measuring line can be integrated in the energy chain. When the measuring line sends a signal, this indicates that the cables or hoses are starting to wear down. This also permits scheduling of replacements.

Example 3: Consumption measurements

Typical consumption values for power and air apply under defined production conditions (reference values). These reference values can be compared to the actual values. If deviations outside of a predefined tolerance range occur, an error message is displayed on the screen. By comparing these values with other parameters, e.g. vibration measurements on the roller bearings, the cause can be determined even more precisely.

Moreover, trends are visualised, meaning that a slow wear can be detected and maintenance can be planned in good time.

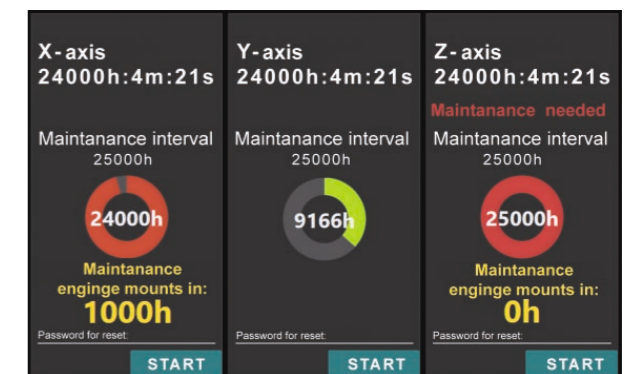

For electric motors, the total on-time is determined and compared with a calculated service life. When a specific value is reached, the system notifies the user accordingly, so that maintenance can be scheduled for a non-production period.

Other functions such as calculation of totals show the total consumption within any desired period. This permits precise calculation of production costs.

